

BlueBee

User Manual v1.00

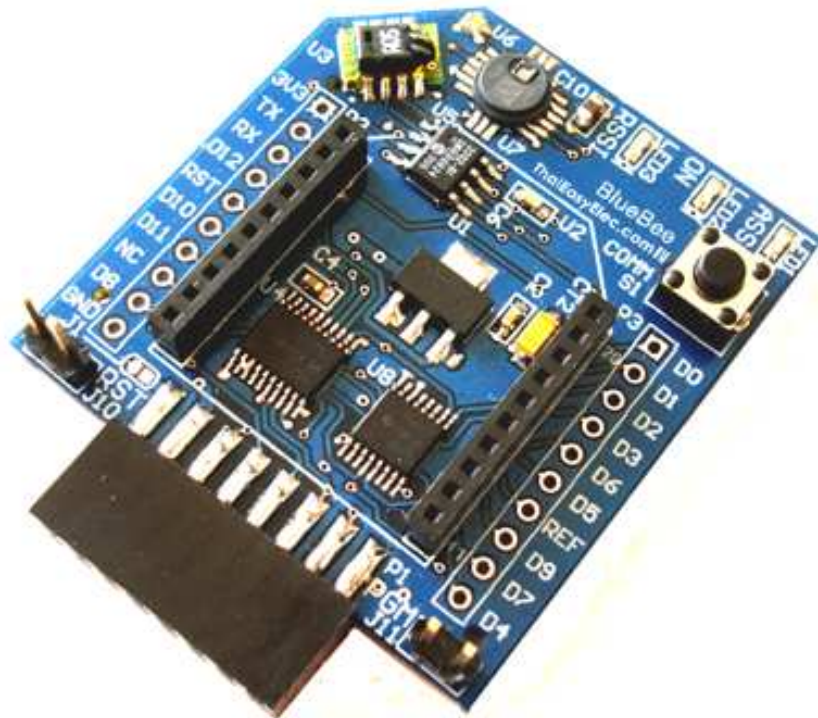

Enable Your Design
ThaiEasyElec.com 
On-Line Electronics Shop for Embedded System

Copyright © 2011, ThaiEasyElec , All rights reserved

Disclaimer:

This document is intended only to assist the reader in the use of the product. ThaiEasyElec.com shall not be liable for any loss or damage arising from the use of any information in this document or any error or omission in such information or any incorrect use of the product.

Table of Content

Introduction	3
Feature	3
Options	4
Requirement	4
Drawing	5
Getting Start	6
- Peripherals	6
- Hardware description	7
- Flow control enabling	9
- Firmware updating	11
Appendix	12
- Unavailable communication resolving	12

1. Introduction

BlueBee (part number ETEE017) is Zigbee base board which contains two of 10-pin 2mm-pitch connectors for Digi's Xbee module. Including with on-board footprints for various types of sensor, it supports temperature and humidity sensor SHT11 (or SHT15), ambient light sensor TPS852 and absolute pressure sensor (and also temperature) SCP1000. Easy to interface with 5V-tollerant low voltage buffer 74LVCH245, the board can be interfaced with both 5V and 3V3 MCU (or USB to serial module).

Common BlueBee module consists of Xbee connector, on-board 3V3-regulator, 74LVCH245, TS3A5018 (analog switch IC) and necessary components only. No sensors and companion devices are installed. To order the module with optional sensor(s), please see section 3 "Options".

To upgrade firmware of Xbee module, the board can be seamlessly connected with ThaiEasyElec's USB to serial module (version 2). See more detail in Section 6.4 "Firmware updating".

2. Features

Hardware

- Xbee module's connectors
- Onboard 3V3 voltage regulator
- Onboard logic buffer SN74LVCH245 supporting 5V signals
- 3 LEDs indicating association, connection status and RSSI signal
- Through hole PADs for direct connection with Xbee module
- SHT11 or SHT15 temperature and humidity sensor (optional)
- TS852 ambient light sensor with Microchip's analog to digital IC MCP3202 (optional)
- SCP1000-D01 absolute pressure and temperature sensor (optional)

Software

Drivers

- SHT1x driver (based on NXP's LPC2378)
- SCP1000-D01 driver (based on NXP's LPC2378)
- MC3202 driver (based on NXP's LPC2378)

Demonstrating application

- Wireless sensor network with ThaiEasyElec's BlueScreen board

3. Options

BlueBee can be ordered with various options, depends on user's requirement. The option lists are shown below.

Temperature and humidity sensor, SHT11 or SHT15.

Absolute pressure and temperature sensor, SCP1000-D01.

Ambient light sensor, TPS852 including with ADC MCP3202.

These options are combinable. Required sensor will be installed with companion passive devices.

4. Requirement

- Digi's (or MaxStream's) Xbee module
- USB to serial module, ETEE002 with USB cable (optional)

5. Drawing

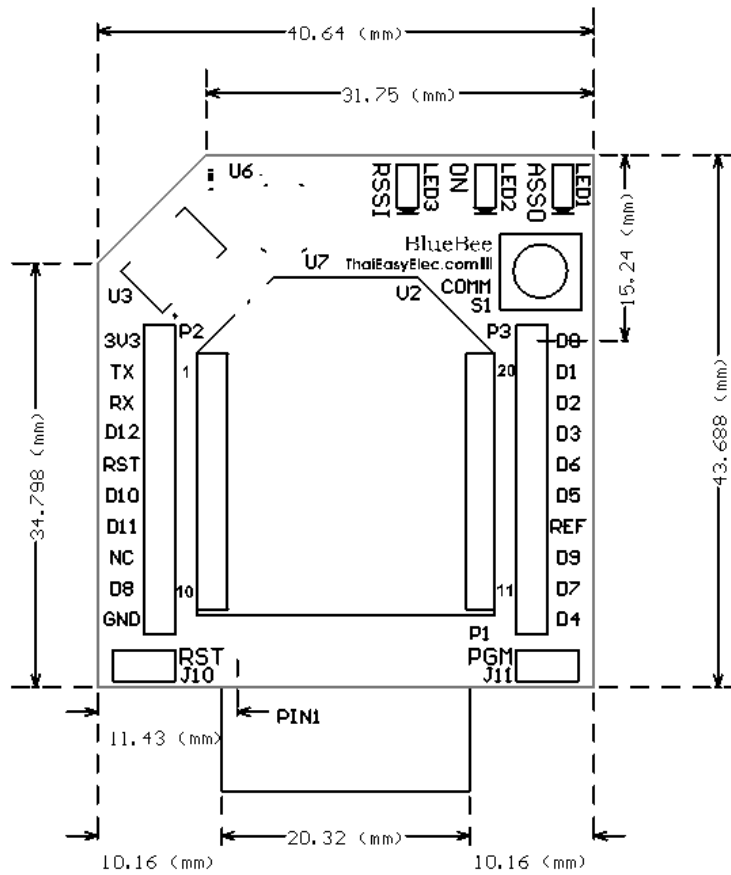

6. Getting start

Peripherals

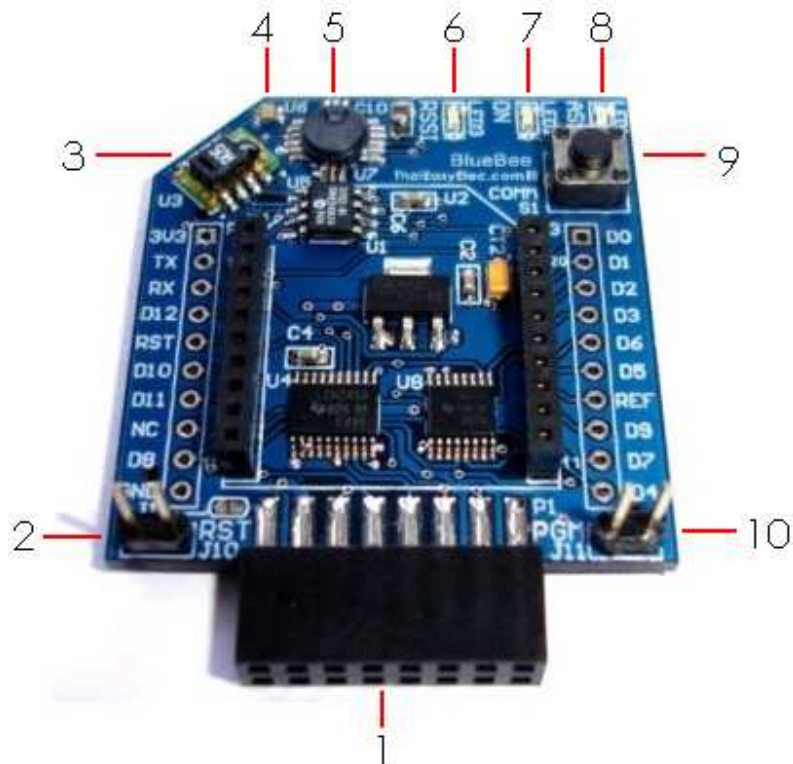

1. ThaiEasyElec's module connector
2. Reset jumper (J10)
3. SHT1x
4. TPS852
5. SCP1000-D01
6. RSSI LED
7. On LED
8. Association LED
9. DIO0 switch
10. Flow control jumper (J11)

Hardware description

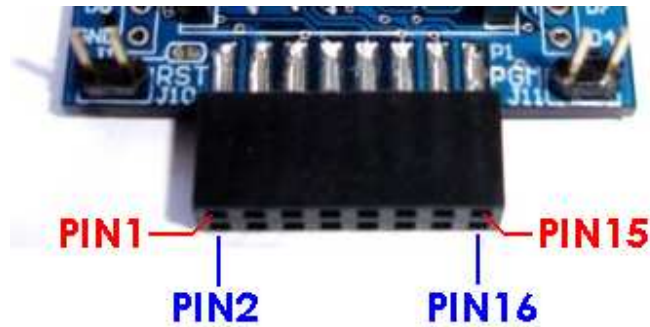

ThaiEasyElec's module connector consists of 3V3, 5V, GND, SPI, UART, and IO signals. The pin arrangement is shown above.

Pin	Name	Description	Connection with BlueScreen*
1	3V3	3V3 from host board (not required)	3V3
2	GND	Ground	GND
3	5V	5V from host board	5V
4	MOD_RST	Xbee reset with on-board pull up	P4.29
5	MISO	MISO pin (connected to all SPI device)	P0.8
6	MOSI	MOSI pin (connected to all SPI device), and also used as DTR	P0.9
7	TX	Xbee's TX	P2.1
8	SCLK	SCLK pin (connected to all SPI device), and also SHT1x's clock	P0.7
9	RX	Xbee's RX	P2.0
10	MOD_CS	Used as MCP3202 CS signal	P0.6
11	MOD_IN	Used as RTS or SCP1000 CS signal or RTS	P0.4
12	MOD_IO	Directly connected to SHT1x's data	P0.5
13	MOD_OUT	Used as DRDY from SCP1000 or CTS	P2.11
14	5V	5V from host board	5V
15	GND	Ground	GND
16	3V3	3V3 from host board (not required)	3V3

BlueBee User Manual

*for more information see

http://www.thaieasyelec.com/index.php?lay=show&ac=cat_show_pro_detail&cid=402&pid=45899

Warning !! DO NOT connect BlueBee to computer if it is connected to microcontroller. BlueBee can only be connected either to computer or microcontroller.

PIN 1, 16 3V3 these two pins are not directly connected to 3V3, since there is on-board regulator supplying 3V3 from 5V. So it's **not required** to supply 3V3 to the module. Anyway, in case users want to use 3V3 for external circuit, connect J1 and J2 by soldering.

PIN3, 14 5V one of these two pins must be supplied with 5V from host board or external power supply.

PIN4 MOD_RST this pin is buffered with 74LVCH245, it's 5V-tolerant. With on-board pull up and headers J10, user can manually reset Xbee module by placing jumper on this headers.

PIN5 MISO this pin is directly connected with MISO pin of SCP1000 and MCP3202.

PIN6 MOSI this pin is buffered with 74LVCH245, it's 5V-tolerant. And also, the pin is used as Xbee's DTR pin for firmware downloading. See more information about function selection on section 6.3 "Flow control enabling".

PIN7 TX output from Xbee module. Connect this pin to MCU's RX pin.

PIN8 SCLK this pin is buffered with 74LVCH245, it's 5V-tolerant. But the pin is also connected directly (not buffered) to SHT1x.

Since SHT1x's DATA pin is bidirectional, it's easier to connect this pin directly with MCU in order to support both 3V3 and 5V MCU. For this manner, the module allow user to select supply voltage by **shorting J4 (for 5V) or J5 (for 3V3)** and in the same time, SHT1x's SCLK pin must

BlueBee User Manual

be directly connected to MCU to support both voltage range. Care must be taken on using SHT1x on the module.

PIN9 RX this pin is buffered with 74LVCH245, it's 5V-tolerant. Connect this pin to MCU's TX pin to communicate with Xbee module.

PIN10 MOD_CS this pin is buffered with 74LVCH245, it's 5V-tolerant. This pin is used as MCP3202's CS pin.

PIN11 MOD_IN this pin is buffered with 74LVCH245, it's 5V-tolerant. This pin is used as SCP1000's CS pin.

PIN12 MOD_IO this pin is directly connected to SHT1x's DAT pin. See PIN8 description about powering SHT1x.

PIN13 MOD_OUT this pin is used as CTS for Xbee module and DRDY from SCP1000. See more information about function selection on section 6.3 "Flow control enabling".

Flow control enabling

To support flow control operation and all sensors, an analog switch IC TS3A5018 is used for signal switching. See circuit below.

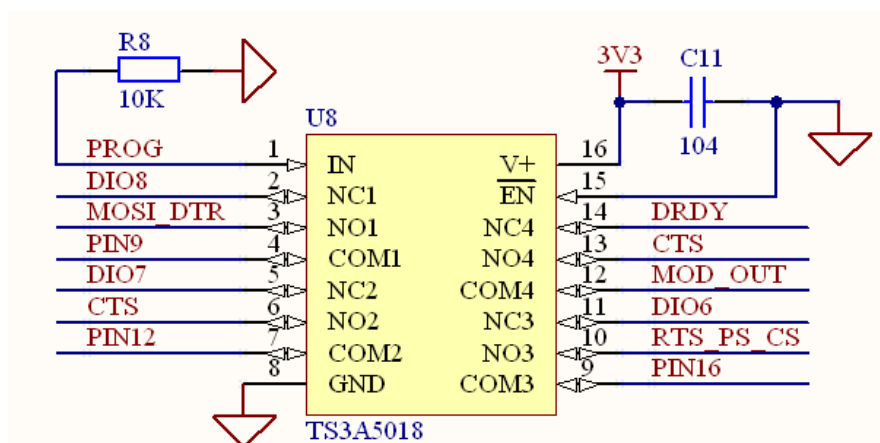

For normal operation the IC's pin1 must be held low. This is done by **leaving J11 open**, and then the connections are below:

BlueBee User Manual

XBEE module's PIN9 -- DIO8
XBEE module's PIN16 -- DIO6
XBEE module's PIN12 -- DIO7
MOD_OUT -- DRDY

To enable flow control operation, the IC's pin1 must be supplied with high logic. This is done by **shorting J11**, and then the connections are below:

XBEE module's PIN9 -- MOSI_DTR
XBEE module's PIN16 -- RTS_PS_CS
XBEE module's PIN12 -- CTS -- MOD_OUT

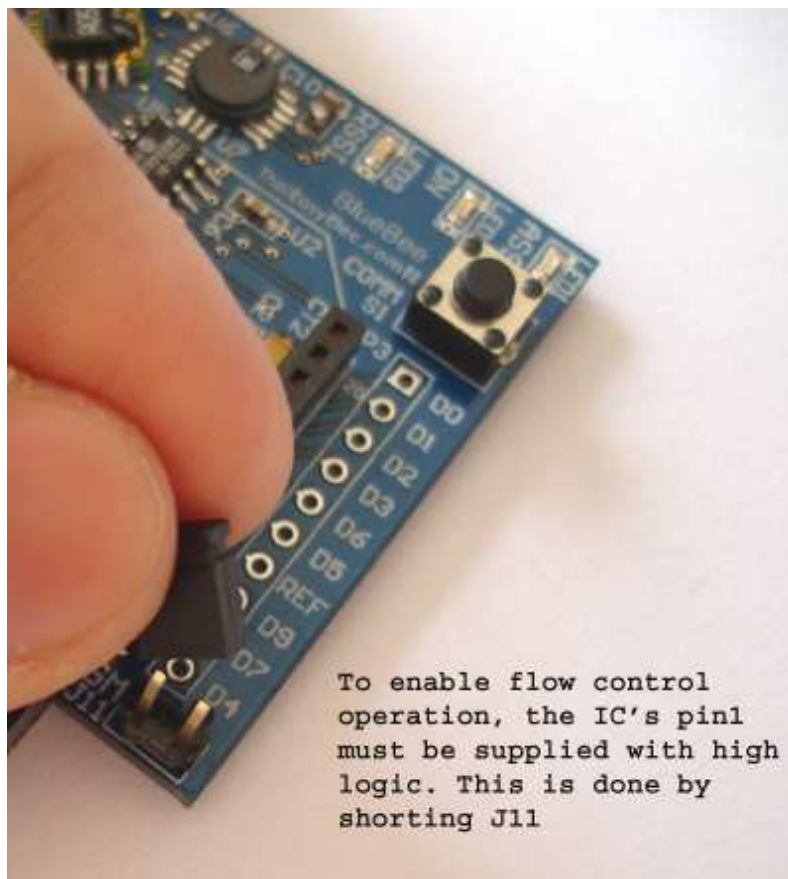

Firmware updating

BlueBee can be cooperatively used with ThaiEasyElec's USB to serial module part number ETEE002 but with a note that **only version 2 of ETEE002 does support flow control behavior (version 1 supports TX and RX signals only)**. Two modules are seamlessly connected as the picture below. Notice a text "#2" on the USB to serial module indicating that it's version 2.

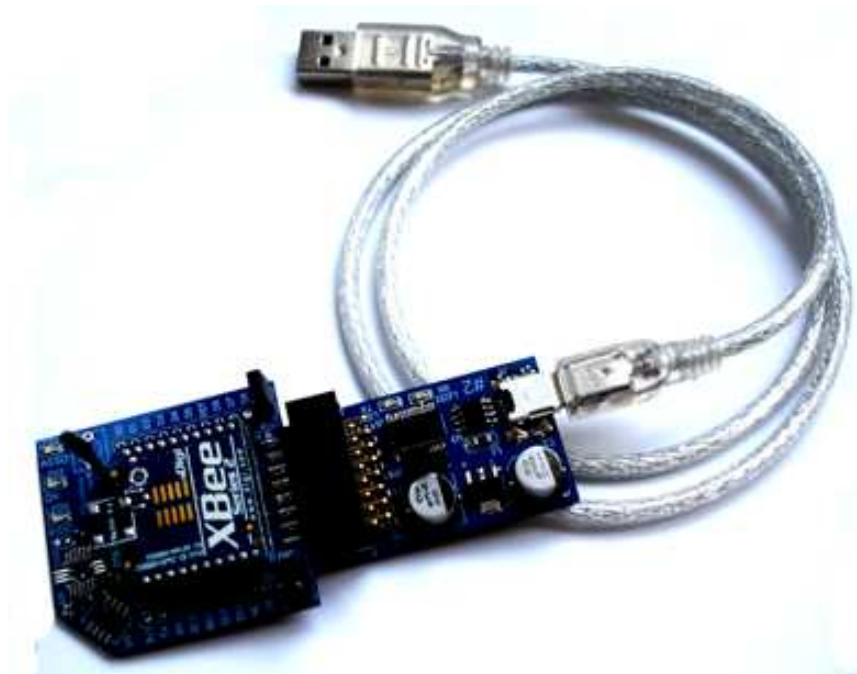

Xbee firmware can be download using Digi's software X-CTU (free download at

<http://www.digi.com/support/kbase/kbaseresultdetl.jsp?kb=125>).

Place jumper on J11 in case flow control is needed in the downloading (normal AT operation doesn't need flow control signals).

Appendix

1. Unavailable communication resolving

If the communication is unavailable (as shown below), easy steps are shown here to fix the problem.

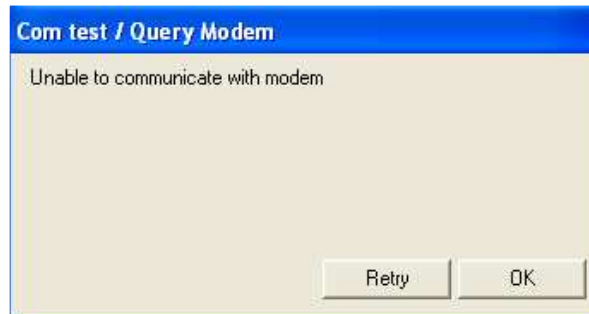

1. Get into “Modem Configuration” tab. Select the right modem type (if you are not sure, try reading another fine module) and make the “Always update firmware” checked. Also select function set to operate.

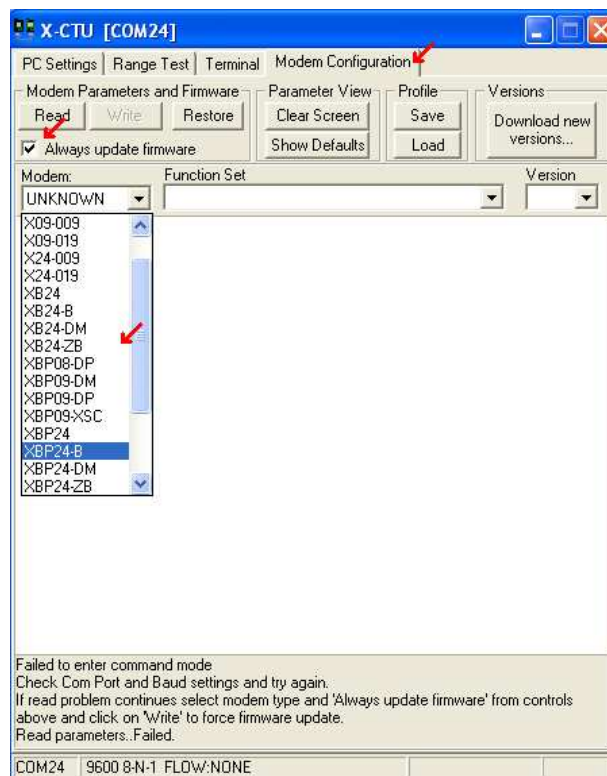

BlueBee User Manual

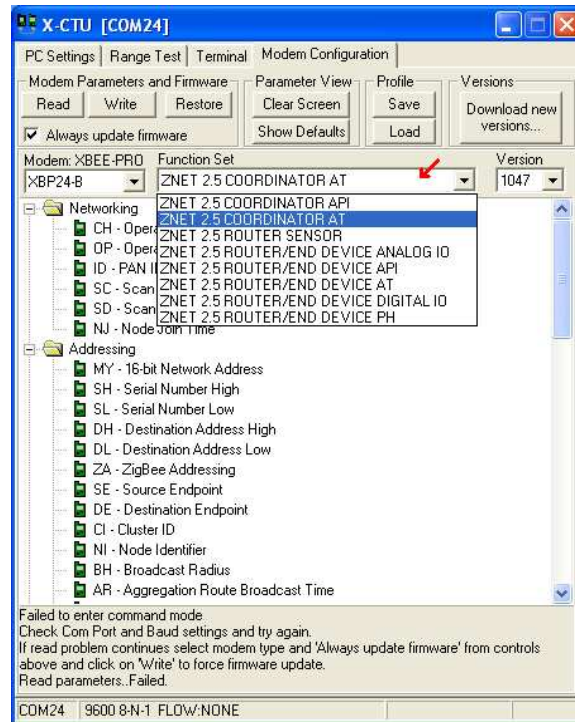

2. Press “Write”, then a popup screen should occur.

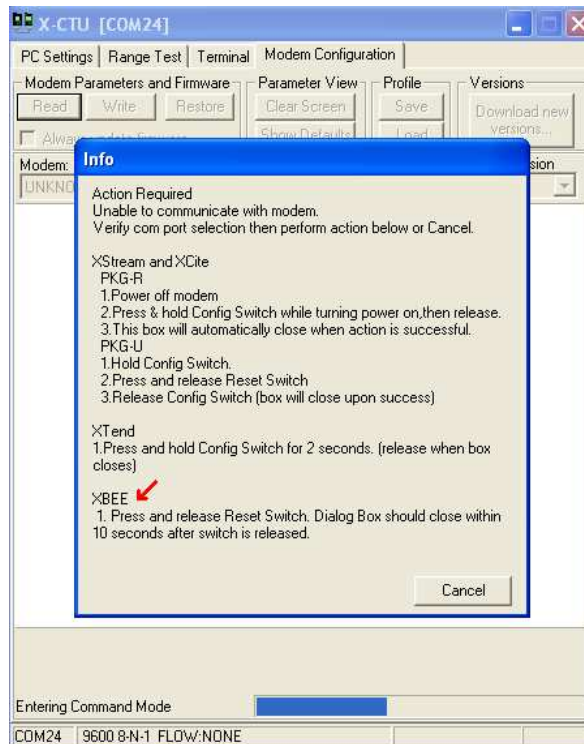

BlueBee User Manual

3. At this step, place a jumper on J10 for a second and then take off to reset the module. The popup screen should close within 10 seconds and the firmware writing begins.

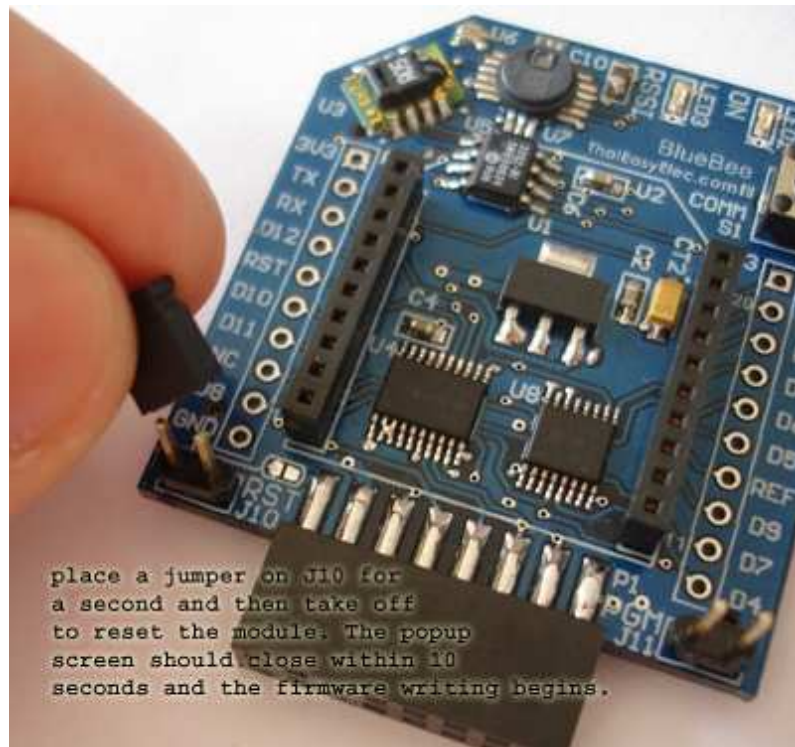

4. Get into “PC Setting” tab. Try “Test/Query”, the communication should be available.



BlueBee User Manual

Prepared by
ThaiEasyElec.com
Venus Supply Co.,Ltd
196/1, Soi Thedsaban-Nimit-Nau 8,
Thedsaban-Nimit-Nau Road, Ladyao,
Chatuchak, Bangkok 10900
Tel. +(66)2954-2408 , Fax. +(66)2953-8443
Email Sale@thaieasyelec.com
Support@thaieasyelec.com